

Characteristic Description

TM512AC is a DMX512 differential parallel protocol LED driver chip with 16-bit gray scale and enhanced gamma correction 2.2, which is more suitable for human visual perception. 4 channel with high precision and constant output. TM512AC decoding technology accurately decodes DMX512 signals, which can be compatible with and expand DMX512 protocol signals. TM512AC completely adaptively decodes DMX512 signals with transmission frequency within 200 kbps ~ 1000 kbps, without setting the rate, and can address up to 4096 channels. TM512AC has built-in E2PROM, which needs no external connection and supports online code writing. the chip provides four high-precision constant output channels with withstand voltage of 30V up to 80ma, and the output size of electricity is set by an external resistor, and it can also have built-in fixed 18mA constant current output. TM512AC has PWM reverse polarity frequency reduction output function, which is suitable for external triode and MOS tube to expand current drive. High port refresh rate greatly improves picture refresh. TM512AC can short-circuit multiple sets of constant output interfaces to expand current drive capability. It is mainly designed for LED lighting system of building decoration and stage lighting effect. The abnormality of one chip does not affect the normal work of other chips at all, and the maintenance is simple and convenient. This product has excellent performance and reliable quality.

Functional Characteristics

- Compatible and extended DMX512(1990) signal protocol
- Control mode: differential parallel connection, maximum support for 4096 channel addressing
- High-speed DMX512 supplements the patent of algorithm, which can completely adaptively decode DMX512 signals with transmission rate of 200 kbps ~ 1000 kbps
- The built-in 485 module has the advantages of high differential signal resolution and large differential input impedance, which can greatly enhance the load-carrying capacity
- Built-in E2PROM, no external E2PROM is needed
- AB line writes code online, which can write code automatically at one time, and supports the mode of writing code after installation first
- E2 address code double backup mode, partial E2 damage does not affect address code reading
- The PWM selector can select the reverse polarity frequency reduction function, and the port refresh rate after frequency reduction is 250Hz
- The output port has 16-bit gray scale control and adopts gamma correction 2.2 enhancement, which is more suitable for human visual perception
- Screen refresh up to 2KHz
- Built-in 5V voltage regulator
- OTR/OUTG/OUTB/OUTW output withstand voltage is greater than 30V
- OTR/OUTG/OUTB/OUTW four-bit constant output channel
- External output constant current adjustable resistor, the current range of each channel is 3 ~ 80mA
- A fixed 18mA constant current output is built into SSOP10 package
- ±3% inter-channel electrical difference value, ±5% inter-chip electrical difference value
- Power-on self-test lights up in blue. After code writing is successful, the first address lights up in red, and other addresses lights up in white for breakpoint identification.
- The new address does not need to be re-powered when it takes effect

- 80 ns output channel hysteresis reduces surge current interference
- Industrial grade design, stable performance
- Package form: SOP16, SSOP10

Application Field

Point light source, line lamp, wall washing lamp, stage lighting system, indoor and outdoor video wall, decorative lighting system

Internal structure block diagram

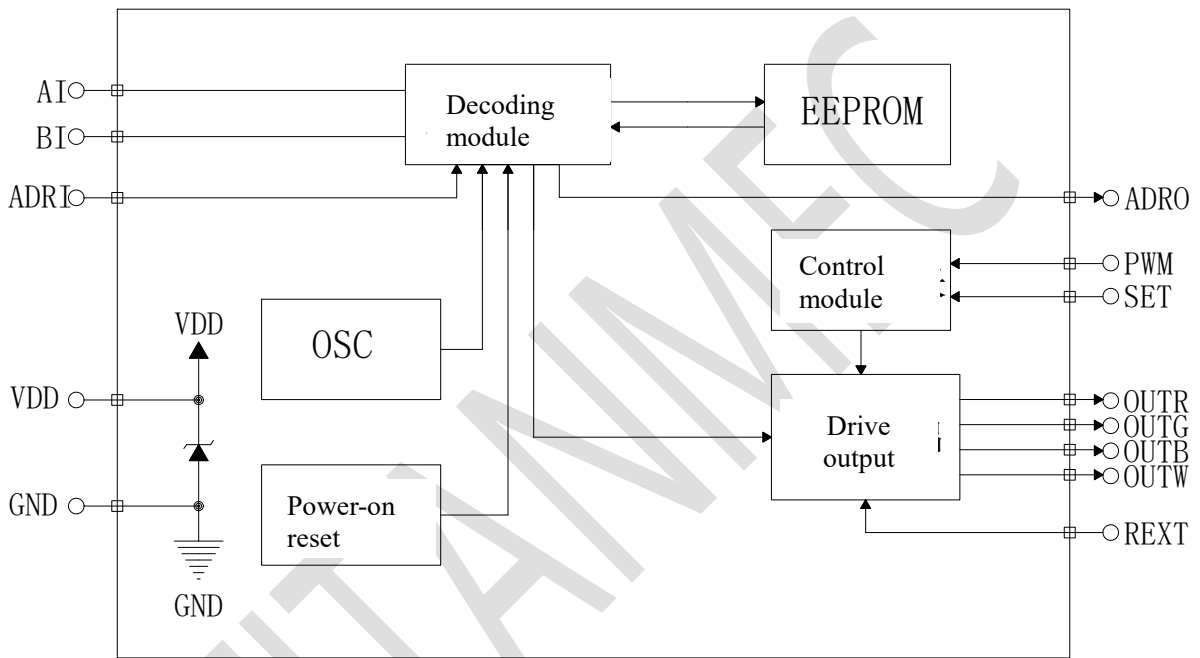

Figure 1

Pin Arrangement of SOP16

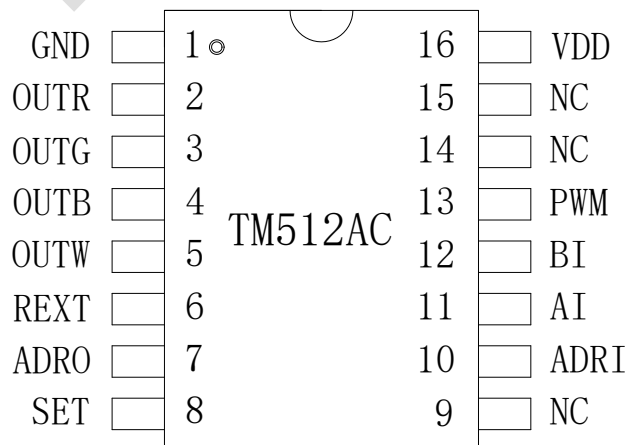

Figure 2

SOP16 pin function

Pin name	Pin serial number	I/O	Function description
GND	1	--	Negative power supply
OUTR/OUTG/OUTB/ OUTW	2~5	O	The PWM output port outputs 65536 gray levels.
REXT	6	I	A constant current feedback end for adjusting the output current to the ground resistance
ADRO	7	O	Address writing code line output
SET	8	--	Power on RGBW state setting pin, suspend OUTB 5% gray output, and connect VDD to close completely
NC	9	--	Empty feet
ADRI	10	I	Address writing code line input, built-in pull-up
AI	11	I	Differential signal, positive, built-in pull-up.
BI	12	I	Differential signal, negative, built-in pull-down.
PWM	13	I	The output polarity is selected, which is generally suspended. After connecting VDD, the output polarity is opposite, and the refresh frequency of the port is reduced to 250Hz
NC	14,15	I	
VDD	16	--	Power cathode

SSOP10 Pin Arrangement

Figure 3

SSOP10 pin function

Pin name	Pin serial number	I/O	Function description
GND	1	--	Negative power supply
OUTR/OUTG/OUTB/ OUTW	2~5	O	PWM output port, fixed 18mA constant current output.
ADRO	6	O	Address writing code line output
ADRI	7	I	Address writing code line input, built-in pull-up

AI	8	I	Differential signal, positive, built-in pull-up.
BI	9	I	Differential signal, negative, built-in pull-down.
VDD	10	--	Power cathode

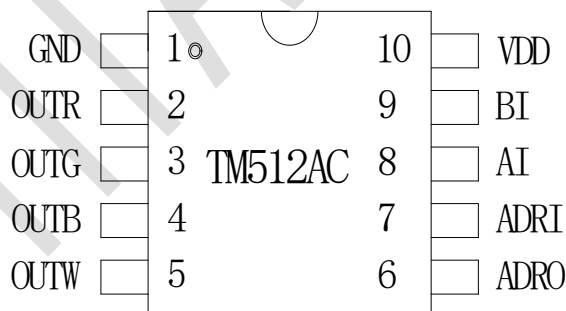
Input / Output Equivalent Circuit

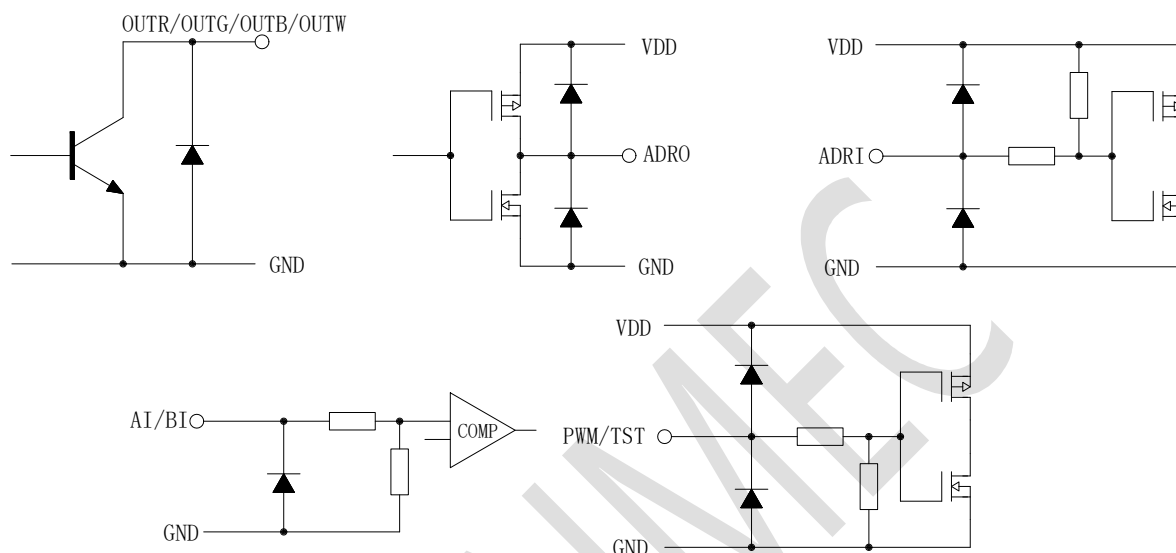

Figure 4



Integrated circuit is an electrostatic sensitive device, which is easy to generate a large amount of static electricity when used in dry season or dry environment. Electrostatic discharge may damage the integrated circuit. Tianwei Microelectronics recommends taking all appropriate integrated circuit preventive measures. Improper operation and welding may cause ESD damage or performance degradation, and the chip cannot work normally.

Working Conditions

1. Ultimate Working Conditions

Tested at 25°C, VDD=5V, unless otherwise specified		TM512AC	Unit
Parameter name	Parameter symbol	limit value	
Logic supply voltage	Vdd	+5.5~+6.5	V
Output port withstand voltage	Vout	30	V
Logic input voltage	Vi	-0.5~Vdd+0.5	V
Working temperature	Topt	-45~+85 (SOP16)	°C
		-45~+65 (SSOP10)	
Storage temperature	Tstg	-55~+150	°C
Antistatic	ESD	4000	V
Package power consumption	Pd	800 (SOP16)	mW
		400 (SSOP10)	

- (1) Long-term operation of the chip under the above-mentioned limit parameters may cause the reliability of the device to be lowered or permanently damaged. Tianwei Microelectronics does not recommend that any parameter reach or exceed these limit values in actual use.
- (2) All voltage values are tested against the system ground.

2. Recommended Working Conditions

Unless otherwise specified, VDD=5V when tested at -40°C~+65°C.			TM512AC			Unit
Parameter name	Parameter symbol	Test condition	Minimum value	Typical value	Maximum value	
Logic supply voltage	Vdd	--	3.8	5.5	6	V
High level input voltage	Vih	--	0.7Vdd	--	Vdd	V
Low level input voltage	Vil	—	0	—	0.3Vdd	V
Output port withstand voltage	Vout				30	V

Chip Parameters

1. Electrical specification

Unless otherwise specified, tested at -40°C~+65°C, VDD = 4.5 V ~ 5.5V, GND=0V.			TM512AC			Unit
Parameter name	Parameter symbol	Test condition	Minimum value	Typical value	Maximum value	
Low level output current	Iol	Vo=0.4V, ADRO	10	-	-	mA
High level output current	Ioh	Vo=4.0V, ADRO	10	-	-	mA
Differential input common mode voltage	Vcm				8	V
Differential input current	Iab	VDD=5V			28	μA
Differential input threshold voltage	Vth	0V<Vcm<8V	-0.2		0.2	V
Differential input hysteresis voltage		Vcm=0V		70		mV
Differential input impedance	Rin			280		KΩ

Output pin current	Isink	OUTR, OUTG, OUTB, OUTW (REXT resistance to ground in SOP16 package)	3		80	mA
Output pin current	Isink	OUTR, OUTG, OUTB, OUTW (SSOP10 package)	-	18	-	mA
High level input voltage	Vih	ADRI	0.7Vdd	-		V
Low level input voltage	Vil	ADRI	-	-	0.3Vdd	V
Current offset (inter-channel)	dlout	Vds=1V, Iout=17mA		±1.5	±3.0	%
Current offset (between chips)	dlout	Vds=1V, Iout=17mA		±3.0	±5.0	%
Voltage offset VS-Vds	%dVds	1V<Vds<3V		±0.1	±0.5	%/V
Voltage offset VS-Vdd	%dVds	4.5V<Vdd<5.5V		±1.0	±2.0	%/V
Dynamic current loss	IDDdyn	VDD=5V	Non-loaded		4	mA
Consumed power	PD	Ta=25°C	-	-	650(SOP16)	mW
			-	-	350(SSOP10)	

2. Switching Characteristics

Unless otherwise specified, tested at -40°C~+65°C, VDD = 4.5V ~ 5.5V, GND=0V.			TM512AC			Unit
Parameter name	Parameter symbol	Test condition	Minimum value	Typical value	Maximum value	
Transmission delay time	Tflz	C1=15pF, Din→Dout, R1=10 KΩ	-	-	300	ns
Falling time	Tthz	C1=300pF, OUTR/OUTG/OUTB/OUTW	-	-	120	us
Data transmission rate	F	-	-	500	1000	Kbps
Input capacitance	Ci	-	-	-	15	pF

Function Description
1. Communication Data Protocol:

TM512AC data reception is compatible with standard DMX512 (1990) protocol and extended DMX512 protocol, and the transmission rate is 200kbps~1000kbps adaptive decoding. The protocol waveform is as follows: the chip is input differentially by AI and BI, and the time sequence waveform of AI is shown in the figure, and BI is opposite to AI.

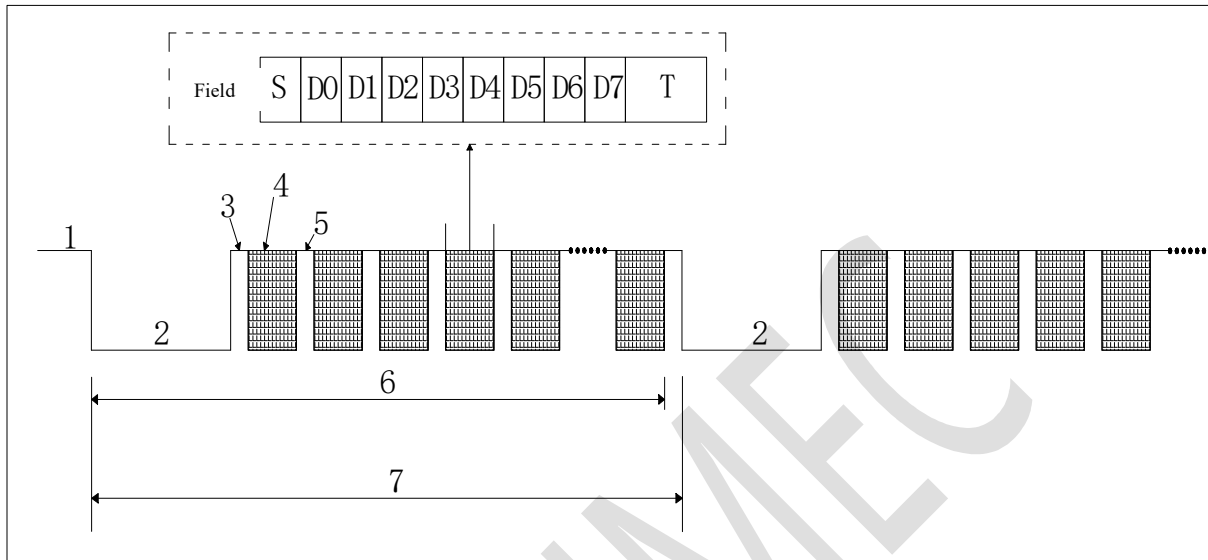

Figure 5

Grade	Describe	Minimum value	Typical value	Maximum value	Unit
	Bit rate	200	500	1000	Kbps
	Bit time	1	2	5	μs
S	Start bit	1	2	5	μs
D0~D7	8-bit data	1	2	5	μs
T	2-bit stop bit	2	4	10	μs
1	Mark before reset	0		1000000	μs
2	reset signal	88		1000000	μs
3	Mark after reset	8		1000000	μs
4	Field (note1)	11	22	55	μs
5	Account for between fields	0		1000000	μs
6	Length of packet	1024		1000000	μs
7	Reset signal interval	4096		1000000	μs

Note1: The field consists of 11 bits, including 0 start bit, 8 data bits and 2 stop bits. Where the start bit of 0 is low level, the stop bit is high level and the data in the data bit is 0, then the corresponding time period is low level; if the data is 1, the corresponding time period is high. 0 The bit length of the start bit stop bit and the data bit must be the same.

2. IC Receiving Instructions:

1. When reset signals appear on AI and BI lines, IC enters the receiving ready state. The address counter is cleared.
2. The first field in the data packet is the starting field, and its 8-bit data must be "0000_0000", which is not used as display data. The valid fields for display start from the second field, and the second field of DMX512 data packet is the first field of valid data. The adaptive data transmission rate of IC is 200 kbps ~ 1000 kbps. The field durations corresponding to different rates are different, but no matter the transmission frequency is 200Kbps/500Kbps/1000Kbps, it is only necessary to ensure that the duration of all valid fields is the same as that of the starting field.
3. According to the address in its E2, IC determines the corresponding field in the intercepted DMX512 data packet. If the chip address is 0000_0000_0000, it is intercepted from the first valid field of the data packet, and the address 0000_0000_0001 is intercepted from the second valid field.
4. When IC receives data, the interval between two reset signals cannot be less than 4ms, and the frame frequency cannot be greater than 250Hz even if the number of parallel connection points is very small.

3. Precautions for the Controller to Send Data:

1. For the standard DMX512(1990) protocol, if a sub-port of the controller is connected to 512 channels, that is, 170 pixels, and the refresh rate is 30Hz, then the time width of each frame is 33.33ms, the time for transmitting 1bit is 4 μ s, and the effective data time width is $88+4\mu s*11bit*512=22.7ms$, then each frame During this time interval, the data line remains high until the next reset signal.
2. TM512AC requires that the reset signal interval of each data packet of the controller should not be less than 4ms, that is, the highest frame frequency should not be higher than 250Hz, otherwise the picture may not be displayed normally.

4. Matters Needing Attention in Writing Code:

1. After the code writing is completed, the IC driving red light of the first address code is always on, and the other address IC driving white lights are always on. The newly written address code takes effect and can be used as breakpoint discrimination.
2. Don't take down the AB line after writing code, and test it with the special test program of the code writer to confirm whether the code is completely correct.
3. The address input terminal lines on the AI and BI ports of the code writer should be pulled out from the code writer after the code writing is completed, so as to avoid wrong code writing when the code writer is out of order. After the code writing line is pulled out, it can be hung up and wrapped with insulating tape without special grounding.

5. Differential Bus Connection Considerations:

1. There must be common ground between controller and IC, and between IC and IC, so as to prevent excessive common-mode voltage from penetrating IC. Multiple IC nodes can be reliably connected by using shielding layer as common ground wire, which can be reliably grounded at one point, but cannot be grounded at two ends or multiple ends.
2. The protection resistors connected in series between AI line and BI line on the board and IC shall be consistent, and the routing mode of AIBI line on the board from pad to IC shall be consistent as far as possible.
3. As far as possible, AI and BI buses shall adopt shielded twisted pair (especially in the common project of high-current and weak-current wiring troughs, near the transmission tower or in areas with more lightning) to reduce interference and lightning impact. Ordinary super-category 5 shielded twisted pair can be used, but pay attention to the purchase of copper wire.
4. In 485 bus, the distance between node 485 and trunk should be minimized. It is

generally recommended that 485 bus adopt hand-in-hand bus topology. The star structure will produce reflected signals, which will affect the communication quality of 485. If the distance between node 485 and the trunk of 485 bus must exceed 1m during construction, it is recommended to use 485 repeater to make a bifurcation of 485 bus. If star topology is required during construction, 485 hub should be used.

5. With the extension of transmission distance, 485 bus will produce echo reflection signal. If the transmission distance of 485 bus is long, it is suggested to connect a 120 ohm terminal matching resistor in parallel with AI and BI lines at the end of 485 communication during construction.

6. Enhanced Gamma Correction 2.2 Description:

1. TM512C has its own gamma correction with a coefficient of 2.2, which corrects 256 gray levels to 65536 gray levels.

2. TM512C adopts enhanced design mode, and the turn-on time of RGBW output is: basic turn-on time+gray time after correction. That is to say, a basic turn-on time is added on the basis of each gray-scale time, which aims to compensate the actual turn-on delay and the large difference of turn-on time of different high-power constant-current driving ICs in high-power applications, so as to ensure that the first-level gray-scale can be obviously felt by human eyes when matched with different high-power constant-current ICs in most cases.

3. Positive polarity: the basic opening time is about 85ns; Reverse polarity: the basic opening time is about 1035ns. The reverse polarity sets a longer basic turn-on time in order to be better compatible with most high-power constant-current driving IC, to compensate its turn-on delay, and to make the first-level gray level be obviously felt by human eyes.

Constant Current Module

1. Output Constant Current Setting:

OUTR, OUTG, OUTB and OUTW are constant current outputs, and the maximum current can reach 80mA. It is not recommended to set the current to a larger value. The value of constant current is determined by the resistance of REXT to ground. the constant current of SSOP10 package is fixed at 18mA, and the current formula is:

$$I_{out} = 48 / (400 + R_{ext}) \quad (1)$$

$$R_{ext} = (48 / I_{out}) - 400 \quad (2)$$

REXT is the resistance connected between Rext pin and ground, in ω , and Ω , I_{out} is the current output by OUTR, OUTG, OUTB and OUTW ports.

Current value (mA)	Rext resistance (Ω)
18	2266.67
20	2000
36	933.33
60	400

The relationship between IOUT current and REXT

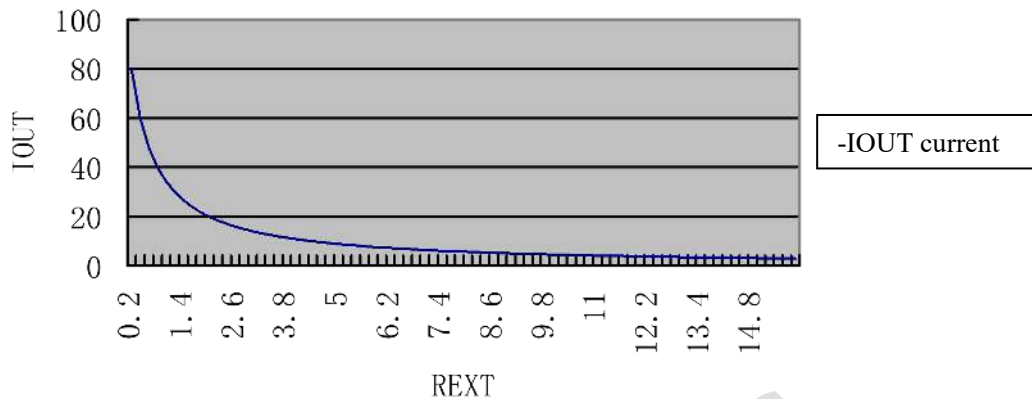

Figure 6

2. Constant Current Curve:

TM512AC has excellent constant current characteristics, and the current difference between channels and even between chips is extremely small.

(1) The current error between channels is $\pm 3\%$, while the current error between chips is $\pm 3\%$.

(2) When the load terminal voltage changes, the output current of TM512AC is not affected, as shown in the following figure.

(3) According to the curve relationship between the current I of TM512AC output port and the voltage Vds applied to the port in the following figure, the smaller the current I is, the smaller the Vds required in constant current state is.

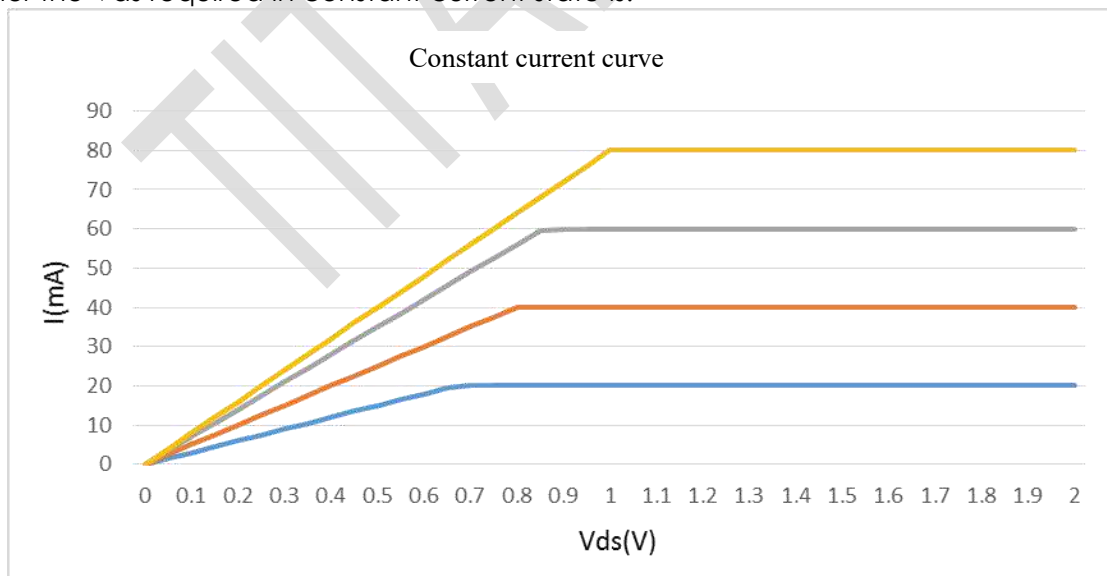

Figure 7

Application Information
1. Application Figure 1: RGBW 4-color application

Figure 8

Note: 1. A and b lines are used to write codes. When writing codes, the code writer/controller does not need to be connected with the ADRI of the first IC.

2. Pay attention to the selection of voltage dividing resistor R1 to avoid excessive power consumption of IC.

3. The REXT port must add a resistor to the ground to set the output current, and this port cannot be left floating.

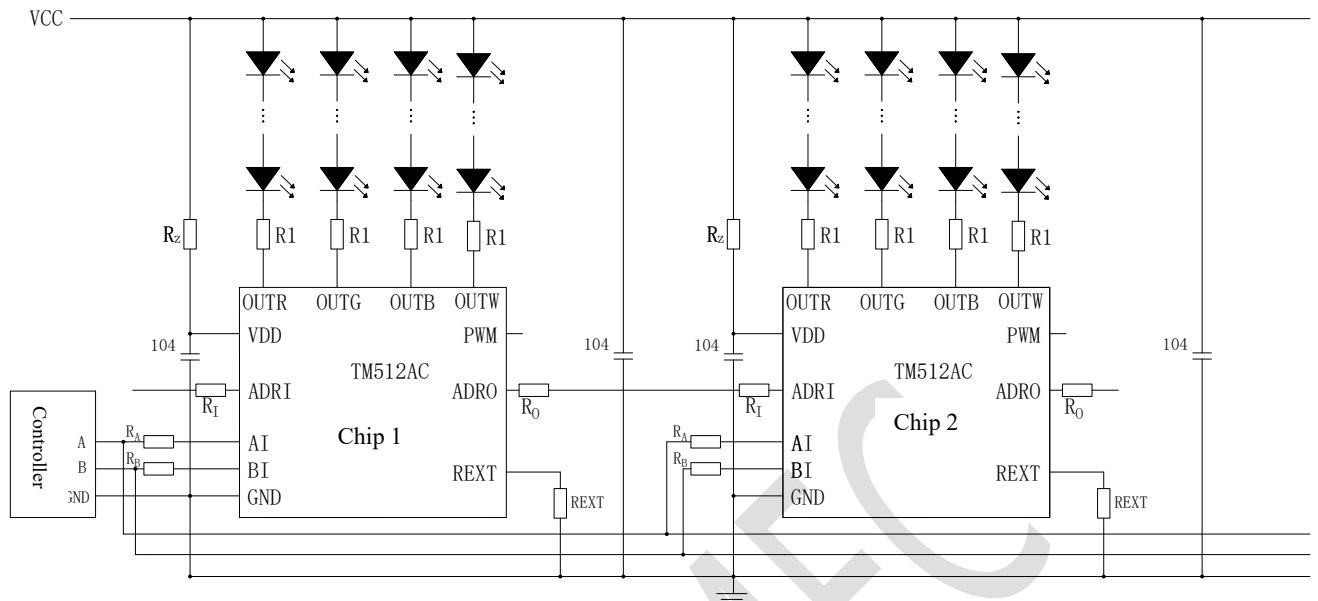
4. The 104 capacitance of VCC to ground is the recommended value when the channel current is set to 20mA. If the channel current is larger, the capacitance value should be increased. For example, if the channel current is set to 40mA, the capacitance value above 105 is recommended.

2. Application Figure 2: RGB 3-color application

Figure 9

Note: 1.A and b lines are used to write codes. When writing codes, the code writer/controller does not need to be connected with the ADRI of the first IC.

2.Pay attention to the selection of voltage dividing resistor R1 to avoid excessive power consumption of IC.

3. The REXT port must add a resistor to the ground to set the output current, and this port cannot be left floating.

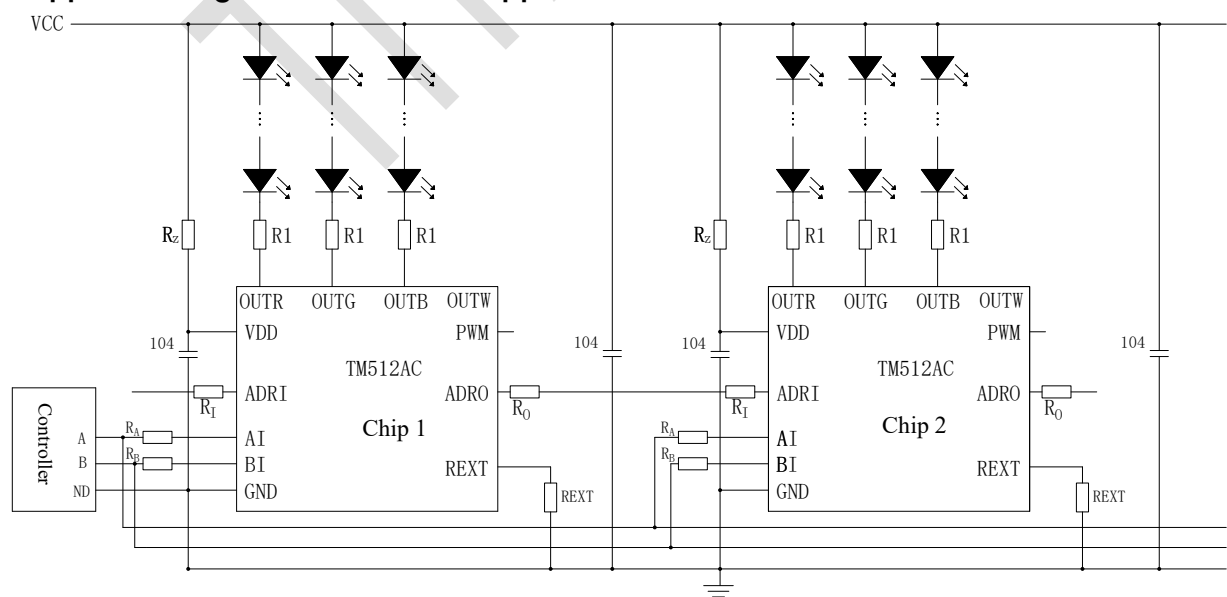
4. The 104 capacitance of VCC to ground is the recommended value when the channel current is set to 20mA. If the channel current is larger, the capacitance value should be increased. For example, if the channel current is set to 40mA, the capacitance value above 105 is recommended.

3. Application Figure 5: Application of External Transistor

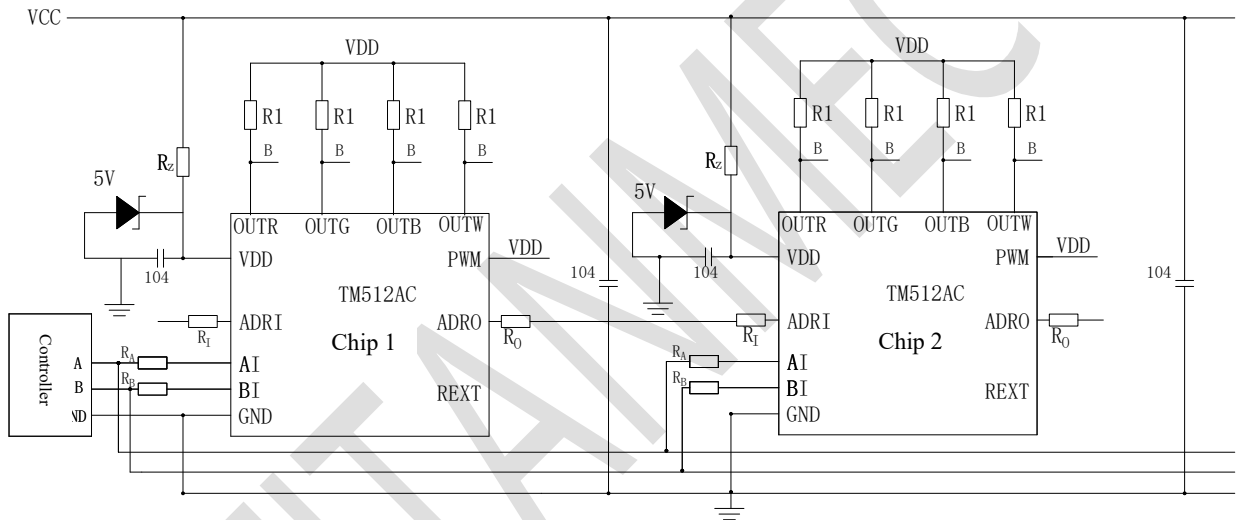

Figure 10

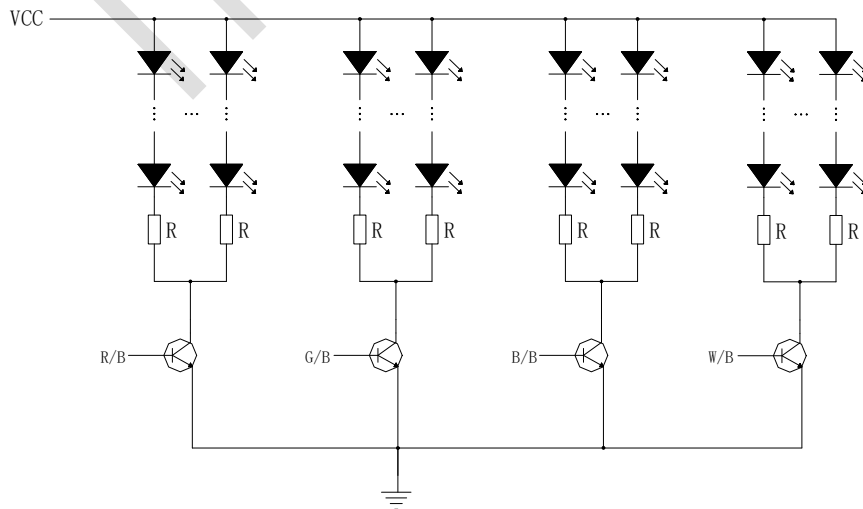

Figure 11

Note: 1. When the PWM pin is connected to VDD, it is reverse polarity frequency reduction constant voltage output, which is suitable for external connection of NPN triode base (B). In application, the output pin is connected with pull-up resistor R1 to VDD, and the pull-up resistor R1 should select the corresponding resistance value according to the triode amplification factor and required current. When the output current is large and the pull-up resistance needs to be less than 5K (the base current is greater than 1mA), the value of the step-down resistance should be reduced accordingly, and a 5V voltage regulator or other 5V voltage regulator should be connected in parallel to VDD.

2. Figure 12 is an application diagram for 4-channel reverse polarity application. Pay attention to PORT0 and PORT1 when other fields are applied in reverse polarity.

3. REXT can be suspended in reverse polarity applications.

4. The 104 capacitance of VCC to ground is the recommended value when the channel current is set to 20mA. If current spreading is used, it is recommended to increase the capacitance to more than 106 to reduce the fluctuation interference of circuit VCC.

4. Application Figure 6: Application of External MOS Tube

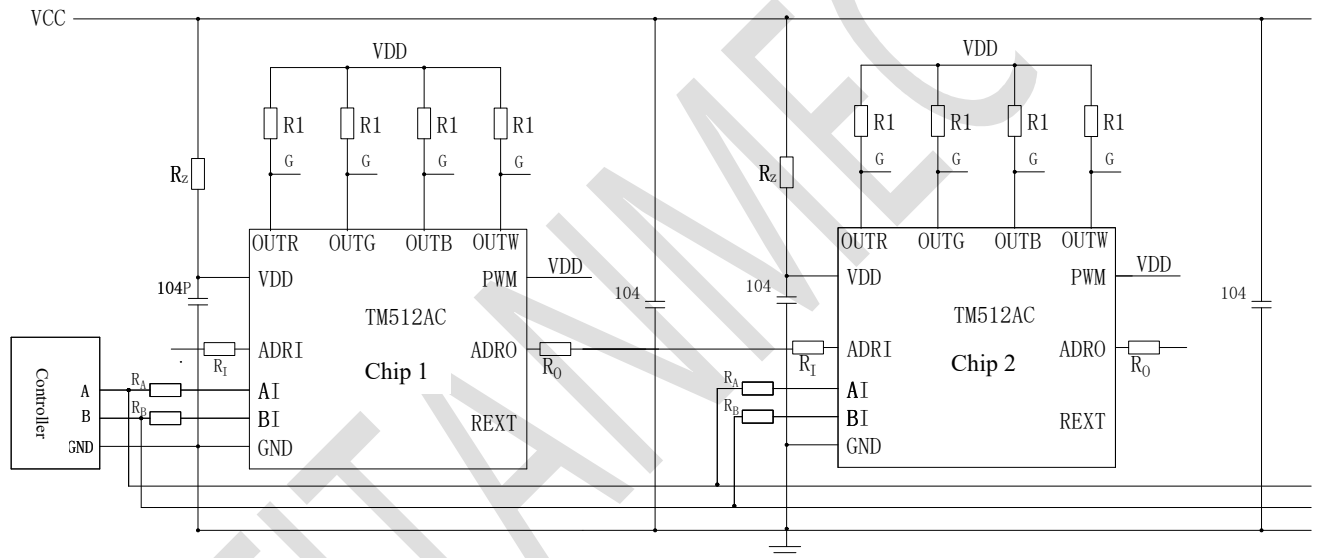

Figure 12

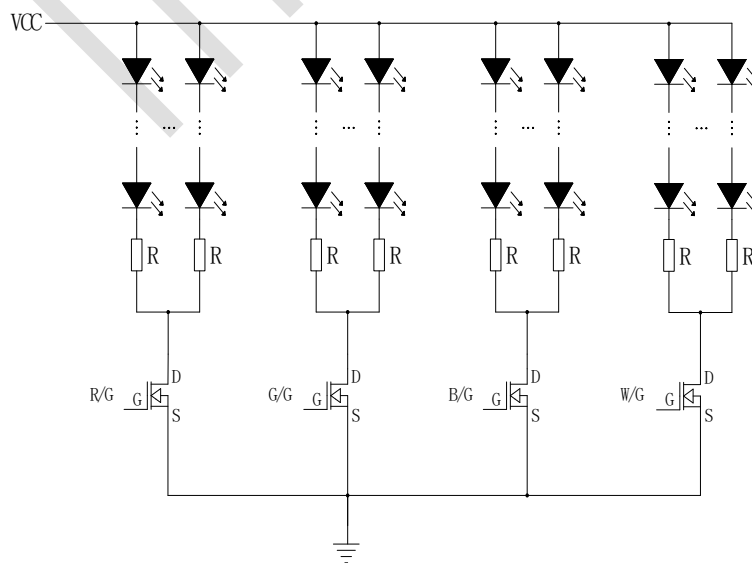

Figure 13

Note: 1. When the PWM pin is connected to VDD, it is reverse polarity frequency reduction constant voltage output, which is suitable for external MOS tube grid (G) or high power constant current drive. In application, the output pin is connected with pull-up resistor R1 to VDD, and the pull-up resistor value is more than 10K. If you want to reduce the brightness of the first gray level, you can increase the pull-up resistor R1.

2. REXT can be suspended in reverse polarity applications.
3. When writing code, do not connect the code writing line to the code writer.
4. High-speed and low-voltage MOS tubes can be selected.

7. Application Figure 7: External Switch Constant Current Drive IC

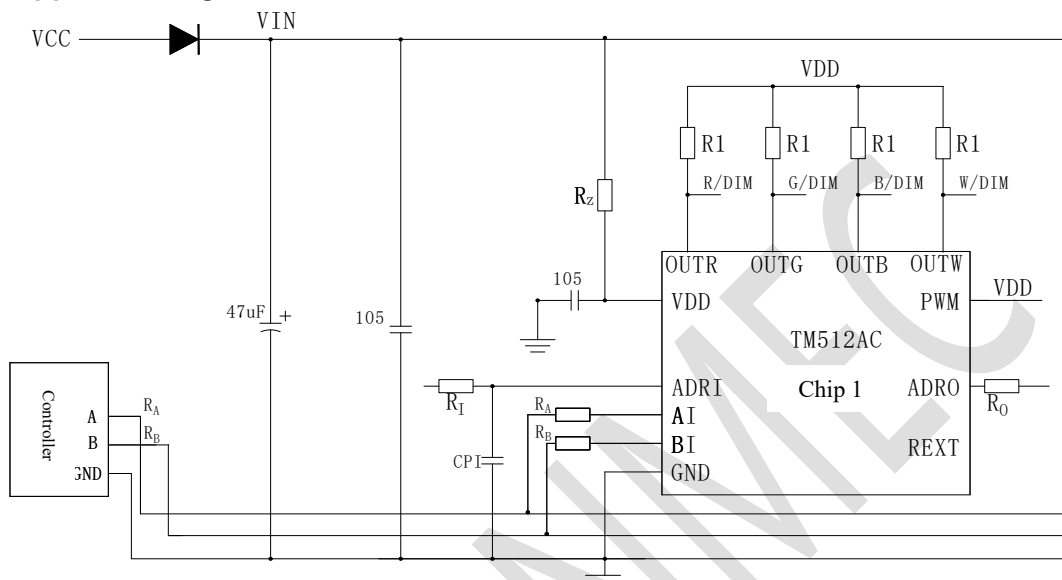
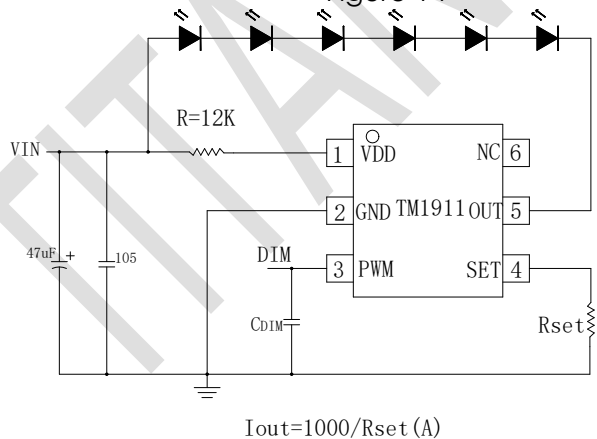

Figure 14



$I_{out} = 1000 / R_{set} (A)$

Figure 15

Note: 1. When the PWM pin is connected to VDD, it is a reverse polarity frequency reduction constant voltage output, which is suitable for external high power constant current drive IC.

2. REXT can be suspended in reverse polarity applications.
3. See TM1911 specification for constant current drive IC components or operation.
4. When switching constant current drive IC is used, the interference may be great (related to various factors such as power wiring), and the system will produce noise and surge. To avoid the problems such as poor code writing or abnormal picture change, the following measures are suggested:

- A. The VDD pin of TM1911 is directly connected with the step-down resistor RZ of TM512AC, which is connected behind the same anti-reverse connection diode. in order to reduce the impact of surge, the VDD of TM1911 and the step-down resistor RZ cannot

be connected behind different anti-reverse connection diodes.

B. The wiring from VDD pin of TM1911 to step-down resistor RZ of TM512AC on circuit board is as thick and short as possible (as close as possible to equipotential), and the wiring between GND pin of TM1911 and GND pin of TM512AC is as thick and short as possible (as close as possible to equipotential).

C. A 47uF electrolytic capacitor and a 105 capacitor are connected to each TM1911 near VDD and GND pins, and a 47uF electrolytic capacitor and a 105 capacitor are connected to TM512AC step-down resistors RZ and GND pins.

D. The AB lines are always wired in parallel on the board, and other components or traces should not be inserted between AB lines under special circumstances (even in special circumstances, they should be limited to the shortest part). Otherwise, the anti-interference function of AB line balanced transmission will be weakened.

E. Under special circumstances, because the PWM pin is disturbed, the control is abnormal. At this time, a capacitor CDIM should be added to GND at the PWM pin of TM1911. The capacitor size depends on the actual situation, and it is usually tens to 100PF.

F. When the interference is too large to write code, a filter capacitor (CPI) can be added between ADRI pin of TM512AC and GND to filter out certain interference, and the capacitor size is generally recommended to be within 103.

8. Component selection table 1 (non-triode application)

	24V	12V	5V
$R_Z (\Omega)$	2K~2.4K	750~820	82
$R_I (\Omega)$	300~500	300~500	
$R_O (\Omega)$	300~500	300~500	
$R_A (\Omega)$	3K~5K	3K~5K	3K~5K
$R_B (\Omega)$	3K~5K	3K~5K	3K~5K

9. Component selection table 2 (triode application, single-channel current not exceeding 120mA)

	24V	12V
R1	2.5K	2.5K
$R_Z (\Omega)$	1 K	300
Is VDD a shunt regulator	Need	Need

(1) Selection of the value of lamp string resistance R

As the long-term power consumption of the package is not recommended to be greater than 650mW, the IC power consumption should be set to be less than 650mW. With the increase of the driving current, the output voltage Vout of the chip channel should be reduced, that is: With $650\text{mW} > 5.2\text{V} \times 10\text{mA} + \text{Vout} \times \text{lout} \times \text{N}$ (N is the number of channels, Vout is the channel port voltage and lout is the channel set current), when N=4 and lout=30mA, $\text{Vout} < 4.98\text{V}$ is obtained, and because $\text{Vout} = \text{VCC} - \text{M} \times \text{VL} - \text{R1} \times \text{lout}$ (M is connected in series on a single channel. When M=8, $\text{R1} > 100\Omega$ is obtained. In addition, in order to keep the output constant current, $\text{Vout} > 0.8\text{V}$ is required, so $\text{R1} < 240\Omega$. In order to make the chip have better output characteristics under the condition that the power consumption meets the requirements, it is recommended that R1 choose an appropriate intermediate value.

Package Diagram: SOP16

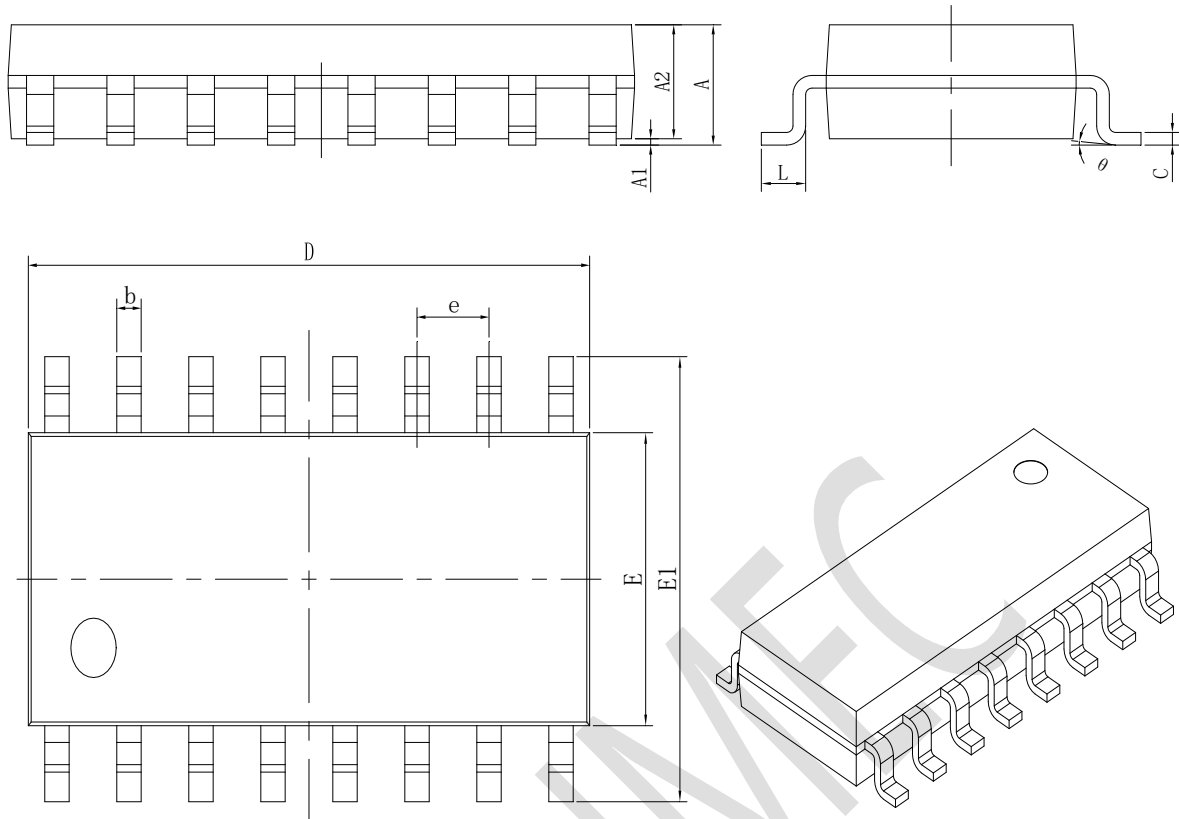

Symbol	Dimensions In Millimeters		Dimensions In Inches	
	Min	Max	Min	Max
A	1.350	1.750	0.053	0.069
A1	0.100	0.250	0.004	0.010
A2	1.350	1.550	0.053	0.061
b	0.330	0.510	0.013	0.020
c	0.170	0.250	0.007	0.010
D	9.800	10.200	0.386	0.402
E	3.800	4.000	0.150	0.157
E1	5.800	6.200	0.228	0.244
e	1.270 (BSC)		0.050 (BSC)	
L	0.400	1.270	0.016	0.050
theta	0°	8°	0°	8°

Package Diagram: SSOP10

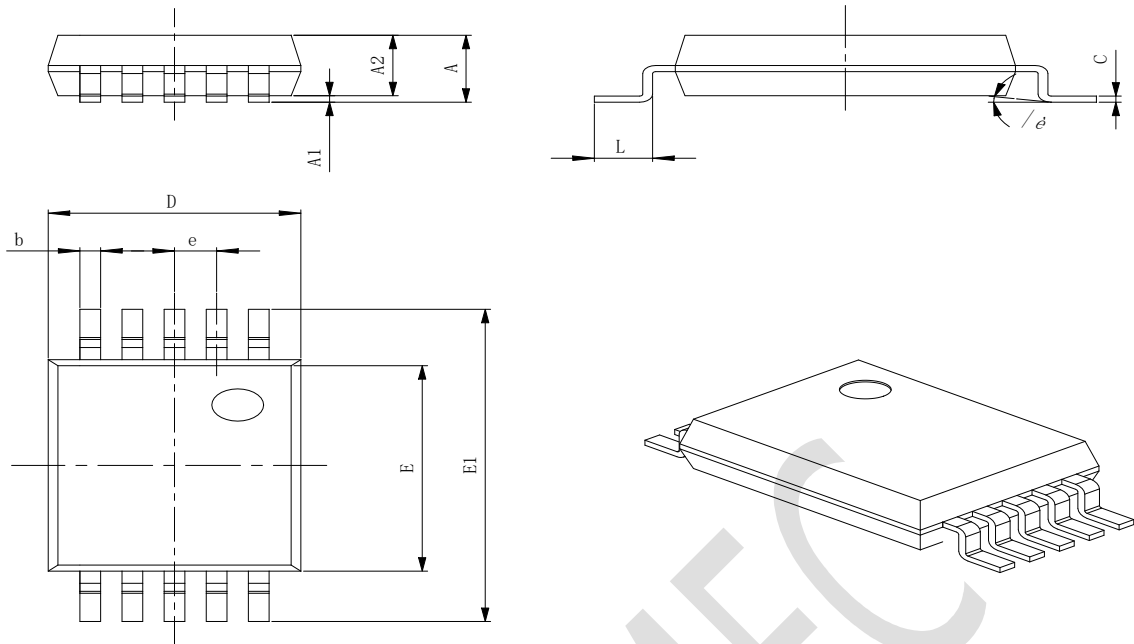

Symbol	Dimensions In Millimeters		Dimensions In Inches	
	Min	Max	Min	Max
A	-	1.75	-	0.067
A1	0.1	0.225	0.004	0.009
A2	1.30	1.50	0.051	0.059
b	0.39	0.48	0.015	0.019
c	0.21	0.26	0.008	0.01
D	4.70	5.10	0.185	0.201
E	3.70	4.10	0.146	0.161
E1	5.80	6.20	0.228	0.244
e	1.0(BSC)		0.039(BSC)	
L	1.05(BSC)		0.041(BSC)	
θ	0°	8°	0°	8°

All specs and applications shown above subject to change without prior notice
(The above circuits and specifications are for reference only. If the company makes corrections, it will not be notified.)