

## Characteristics Description

TM1812 is a 12-channel special circuit for LED driver control internally integrated with circuits of MCU digital interface, data latch and LED HV driver etc. Peripheral MCU control realizes the chip's independent luminance, cascade control realizes color dot matrix illumination control of outdoor big screen, guardrail tube and dream-color LED stripe. This product comes with excellent performance and reliable quality.

## Features

- High power CMOS technology
- 24V output port voltage endurance
- VDD internally integrated with 5V VR-tube
- Chip VDD externally connected with series resistor, 6-24V input voltage supported
- Luminance adjustment circuit with 256-grade luminance adjustment, low brightness equivalent to class 1024
- Single-line serial cascade interface
- Oscillation mode: built-in RC oscillation and clock synchronization in accordance with the data line signal; after data of the unit is completely received, subsequent data can be automatically reshaped and sent to the lower level through the data output end, the signal will not distort or attenuate as the cascade goes further
- Built-in power-on reset circuit
- PWM control end realizes 256-grade adjustment, with scanning frequency no less than 400Hz
- One signal line can complete data receiving and decoding
- When the refresh rate is 30Frames/S, cascade points no less than 1080
- Data sending speed is 800Kbps
- Package form: SOP16, DIP16

## Outdoor applications

Scope: point light source, guardrail tube, flexible light strip, indoor and outdoor big screen etc.

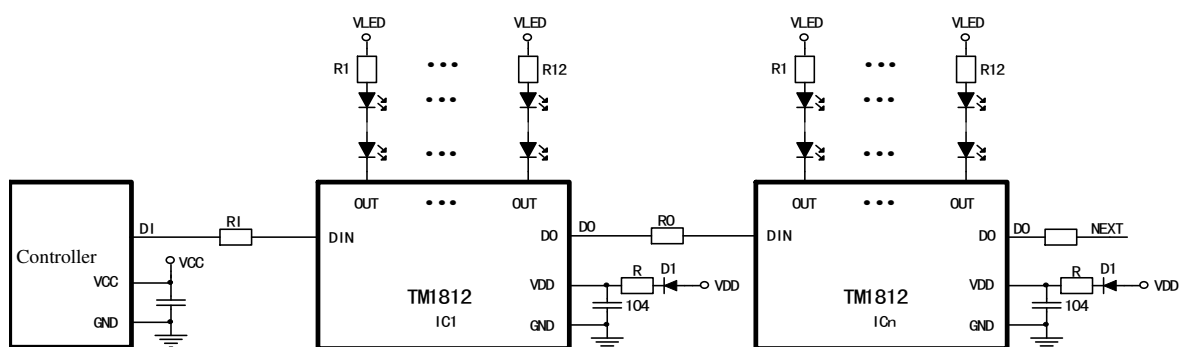

**Internal construction**

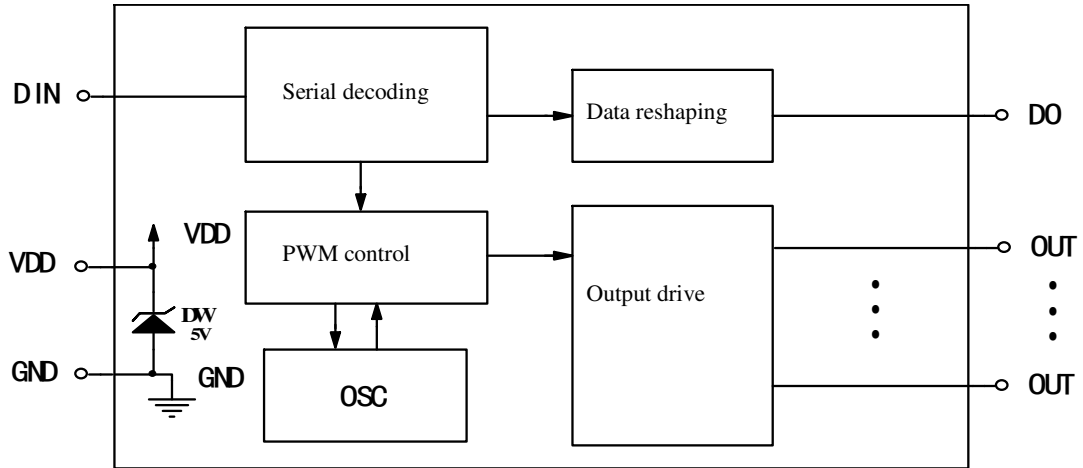

**Pin info**

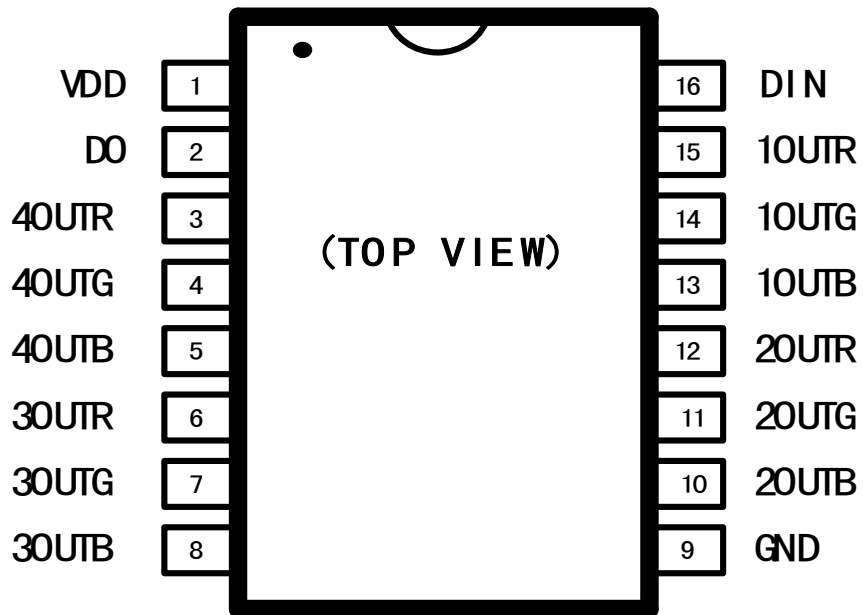

**TM1812**

**Output & input equivalent circuit**

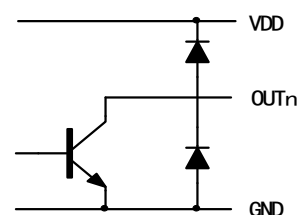
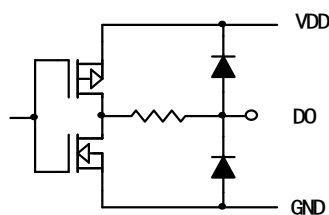
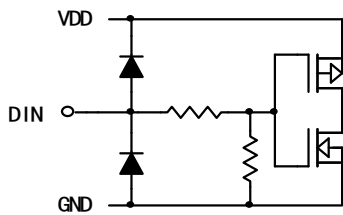

**Pin function**

Port		I/O	Function description
Designation	Pin		
DIN	16	I	Display data input
DO	2	O	Display data cascade output
1OUTR	15	O	Channel 1 Red PWM control output
1OUTG	14	O	Channel 1 Green PWM control output
1OUTB	13	O	Channel 1 Blue PWM control output
2OUTR	12	O	Channel 2 Red PWM control output
2OUTG	11	O	Channel 2 Green PWM control output
2OUTB	10	O	Channel 2 Blue PWM control output
3OUTR	6	O	Channel 3 Red PWM control output
3OUTG	7	O	Channel 3 Green PWM control output
3OUTB	8	O	Channel 3 Blue PWM control output
4OUTR	3	O	Channel 4 Red PWM control output
4OUTG	4	O	Channel 4 Green PWM control output
4OUTB	5	O	Channel 4 Blue PWM control output
VDD	1	-	DC 5V±10%, built in 5V VR-tube, external series resistor is required
GND	9	-	System grounding



In dry season or dry application environment, a great deal of static electricity can be generated, the discharge of which can damage the integrated circuit. Titan Micro Electronics suggests taking all appropriate IC protection measures. Inappropriate operation and welding may cause ESD damage or degraded performance, resulting in failure of chip.

**Absolute max rating range <sup>(1)</sup> <sup>(2)</sup>**

Parameter			Range	Unit
VDD	Logic supply voltage		-0.5 ~+7.0	V
VIN	Input end voltage range	DIN,SET	-0.5~VDD+0.5	V
IOUT	Output end current (DC)	OUTR,OUTG,OUTB	60	mA
VOUT	Output end voltage range	OUTR,OUTG,OUTB	-0.5~+30.0	V
FCLK	Clock frequency	DIN	800	KHZ
Topr	Operating temperature range		-40~+85	°C
Tstg	Storage temperature range		-55~+150	°C
ESD	Human body mode (HBM)		2000	V
	Machine mode (MM)		200	V

(1) For the ratings in the above table, when the chip is in long time service, permanent damage may occur to the device, reducing device's reliability. We do not recommend allowing the chip to work at these max parameters under any other conditions.

(2) All voltage values are tested relative to the system grounding.

**Recommended operating range**

(Unless otherwise specified, GND=0V under condition of -40°C~+85°C)

Parameter		Test condition	TM1812			Unit
			Min value	Typical value	Max value	
<b>DC parameter spec: VCC= DC4.5V~6.5V</b>						
VCC	Supply voltage		4.5	5.0	6.5	V
VO	Output end voltage endurance range	OUT			24.0	V
VIH	High electric level input voltage		3.8		VDD	V
VIL	Low electric level input voltage		GND		1.5	V
IOH	High electric level output current	VCC=5.0V,SDO=4.8V		1		mA
IOL	Low electric level output current	VCC=5.0V,SDO=0.5V		10		mA
IOLC	RGB channel low electric level sinking current	OUTR, OUTG, OUTB = 0.5V		40	45	mA
TA	Operating temperature range		-40		+85	°C
TJ	Operating junction temperature range		-40		+125	°C

**Electric characteristics**

(Unless otherwise specified, typical values are VCC=5V and TA=+25°C under condition of VCC=4.5V~6.5V and -40°C~+85°C)

Parameter		Test condition	TM1812			Unit
			Min value	Typical value	Max value	
VOH	High electric level output voltage	IOH=-6mA:DO	VDD-0.5		VDD	V
VOL	Low electric level output voltage	IOL=10mA:DO			0.5	V
IIN	Input current	DIN =connected to VCC or GND	-1		1	uA
IDD	VDD current	OUTR, OUTG, OUTB ,DIN, DO=open circuit, VDD=5.0V	1	3	5	mA
IOLC	RGB channel low electric level sinking current	OUTR, OUTG, OUTB open=0.5V		40	45	mA
IOLKG	Output leakage current	OUTR, OUTG, OUTB =OFF			0.1	uA
<b>T<sub>PWM</sub></b>	<b>OUT port duty ratio cycle</b>	<b>Out connected to 1K pull-up resistor</b>	<b>1</b>	<b>1.3</b>	<b>1.5</b>	<b>ms</b>
IDDdyn	Dynamic current loss	OUTR, OUTG, OUTB =OFF DO=open circuit			1	mA
<b>Rth(j-a)</b>	Thermal resistance	--	<b>79.2</b>		<b>190</b>	<b>°C/W</b>
<b>PD</b>	<b>Power consumption</b>	<b>(Ta=25°C)</b>			<b>250</b>	<b>mW</b>
RON	RGB port ON resistance	VDD=5.0V	13	-	14	ohm

**Switch characteristics**

(Unless otherwise specified, typical values are VCC=5V and TA=+25°C under condition of VCC=4.5V~6.5V and -40°C ~+85°C)

Sign	Parameter	Test condition	Min value	Typical value	Max value	Unit
fosc2	High speed mode	--	-	800	-	KHz
tPLZ	Transfer delay time	DIN → DOUT			300	ns
tPZL	--	CL = 15pF, RL = 10K Ω			100	ns
TTHZ	Fall time	CL = 300pF, OUTR/OUTG/OUTB			120	μs
Fdat	Data transfer rate	Duty ratio 50%	-	800	-	Kbps
CI	Input capacity	--			15	pF

**Function description**

The chip adopts single line communication method, and sends signal using return-to-zero code. After power-on reset, the chip receives data transferred from DIN end; after 4 groups of 24bit data are received, DO port begins to forward data to provide input data for the next chip. Before forwarding, DOUT port always pares down. At this moment, the chip will not receive new data, the 4 groups of OUTR, OUTG and OUTB output ports of the chip send out signals of different duty ratios corresponding to the data received, with the signal cycle at 1.3ms. If the input signal at the DIN end is signal RESET, the chip will send the data received to the display; the chip will begin to receive new data after that signal is ended. After the started 4 groups of 24bit data are completely received, the data will be sent through the DOUT port.

The chip adopts auto-reshaping forwarding technology, which can thoroughly avoid the problem of signal attenuation and distortion at long distance transfer with multiple points, therefore, the number of cascades of the chip will not be limited by the signal transfer, but be limited by the refresh rate requirement only.

**96bit data structure**

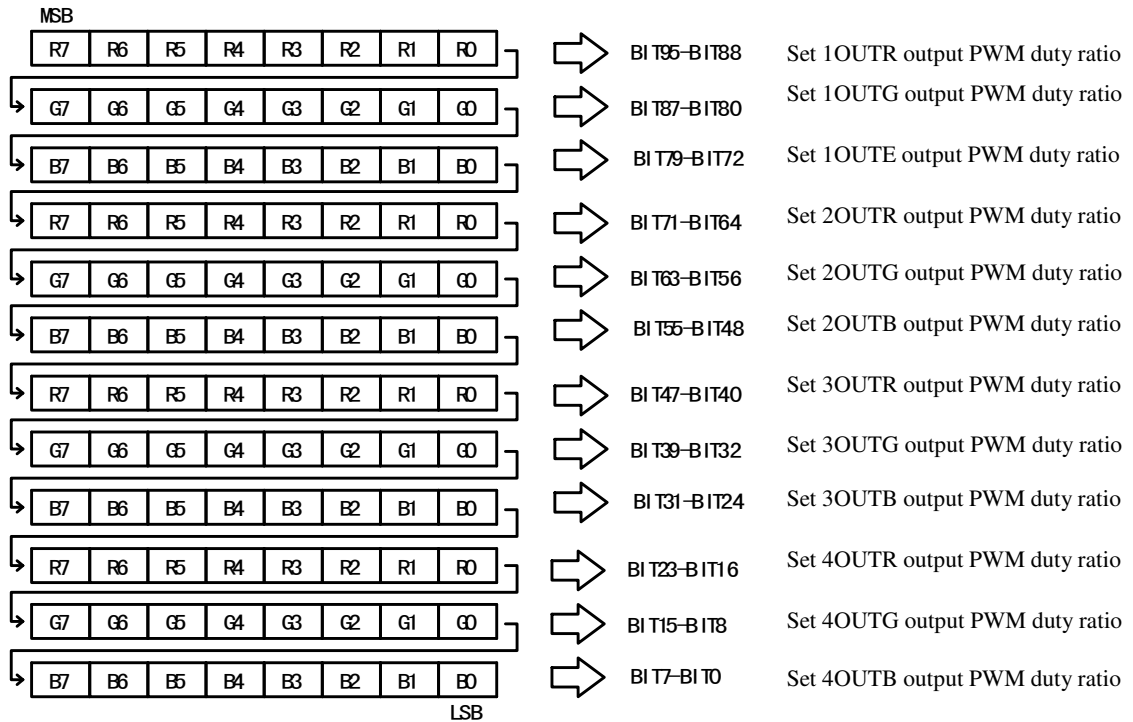

High order first, data is sent in RGB order.

**High speed mode time**

Sign	Parameter	Test condition	Min value	Typical value	Max value	Unit
T0H	Input 0 code, high electric level time	VDD=5.0V GND=0V	350	400	450	ns
T1H	Input 1 code, high electric level time		700	850	1000	ns
T0H'	Output 0 code, high electric level time		--	320	--	ns
T1H'	Output 1 code, high electric level time		--	700	--	ns
T	Cycle time of 0 code or 1 code		--	1.25	--	us
Treset	Code Reset, low electric level time		8	24		us

**Note:** in high speed mode, the cycle time for sending code 1 or 0 is 1.25us (frequency @ 800KHz). The low electric level time between bytes shall not exceed 8us, otherwise the chip will be reset, and begin to receive new data again, failing to realize data transfer.

**Sequence diagram**

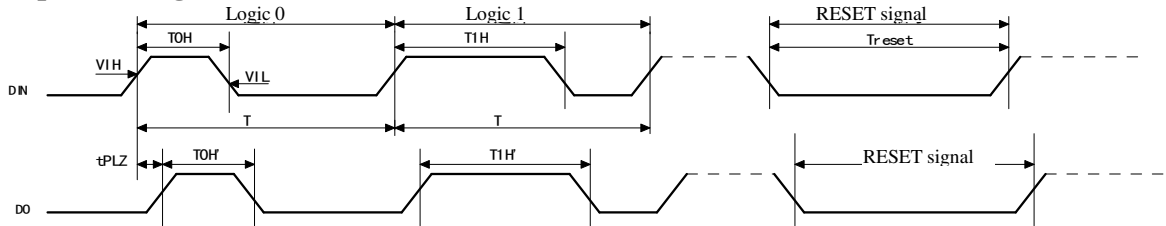

**Data transfer & forwarding**

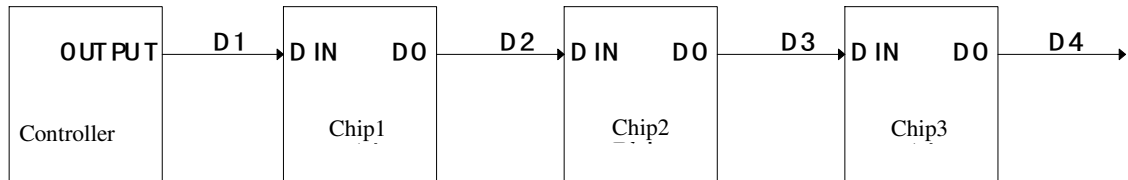

Wherein D1 is the data sent by the controller, D2, D3 and D4 are data sent by TM1812

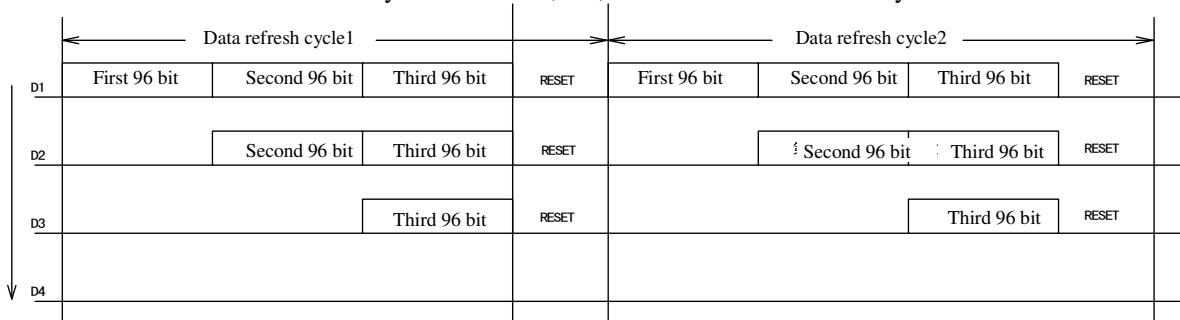

Chip cascading and data transfer & forwarding process: controller sends data (D1), when chip1 receives the first 96bit, chip1 hasn't forwarded data (D2); then the controller keeps on sending data, chip1 receives the second 96bit; Since chip1 has had the first 96bit, chip1 forwards the second 96bit through DO, chip2 receives data forwarded by chip1 (D2); at this moment, chip2 hasn't forwarded data (D3); controller keeps on sending data, chip1 forwards the third 96bit received to chip2; since chip2 has had a 96bit, chip2 forwards the third 96bit (D3), chip3 receives the third 96bit; at this moment, if the controller sends a

RESET low electric level signal >15us, all chips will reset and decode the 24bit data respectively received and control the RGB port to output, completing a data refresh cycle, and the chips return to ready-to-receive status again.

**Application info**

1. How to calculate data refresh rate

Data refresh time is calculated based on the number of pixels cascaded in the system; generally, a group of RGB is a pixel, one TM1812 chip controls 4 pixels. E.g., when the refresh rate is 30 frames/second, the calculation of the number of pixels controllable by the chip is as follows:

(1) 30 frames/second is to say that the time per frame is  $t_1 = 1S \div 30 = 0.033333S = 33333\mu S$ ;

(2) 1 data Bit cycle is  $1.25\mu S$ , and the data to be received per pixel is 24 Bits, therefore, the time required for transferring one pixel is:  $t_2 = 24 \times 1.25\mu S = 30\mu S$ .

(3) The number of pixels controllable is  $N = t_1 / t_2 = 33333\mu S \div 30\mu S = 1111$ .

Based on the number of pixels obtained from the above calculation, reducing the latency of the chips and conductors, the conservative conclusion is: when the refresh rate is 30 frames/second, cascade-controlled 1024 pixels (256 pieces of TM1812 cascade) will have no any flickering.

The table below shows the corresponding relationship between the cascaded pixels and the max data refresh rates:

Pixel	High speed mode	
	Fastest one refresh time (mS)	Max refresh rate (Hz)
1~50	1.44	694
1~100	2.88	347
1~200	5.76	174
1~400	11.52	87
1~800	23.04	43
1~1000	28.8	35

If the system does not require high data refresh rate, and has no requirement on the number of the cascaded pixels, as long as power supply is normal, theoretically, infinite TM1812 cascade can be used.

2. Application circuit and power supply configuration

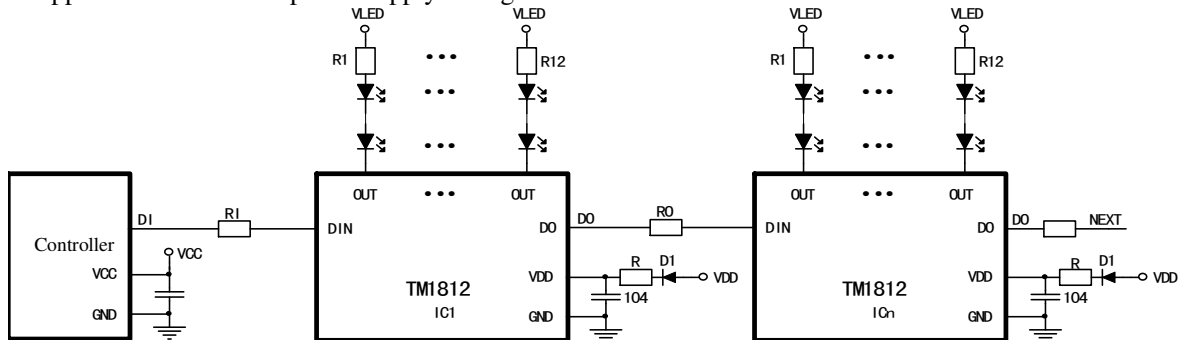

Resistance values of R1-R12 can be automatically adjusted based on the number of the LEDs cascaded at the OUT port, it is recommended to connect 100-200 Ohm resistor to R1 and R0 for signal isolation to prevent the effect of the lower level chip to the higher level chip.

TM1812 can be configured for 6-24V supply; however, depending on the different input voltages, different supply resistor shall be configured. The resistance values are listed below:

Supply voltage	Recommended resistance value R for the supply-VDD connection	Remark
6V	330	If use DC=5V for direct power supply, R resistor is not required; D1 diode is to prevent the chip from being burned due to reversed power supply connection.
9V	1.2K	
12V	2.4K	
24V	6.8K	

3. Use TM1812 for current amplification

In actual application, high power LED or multiple LEDs need to be driven. To obtain higher drive current, current amplification can be done using the method below, appropriate PNP triode or P channel MOS tube (field-effect tube) shall be selected based on LED power.

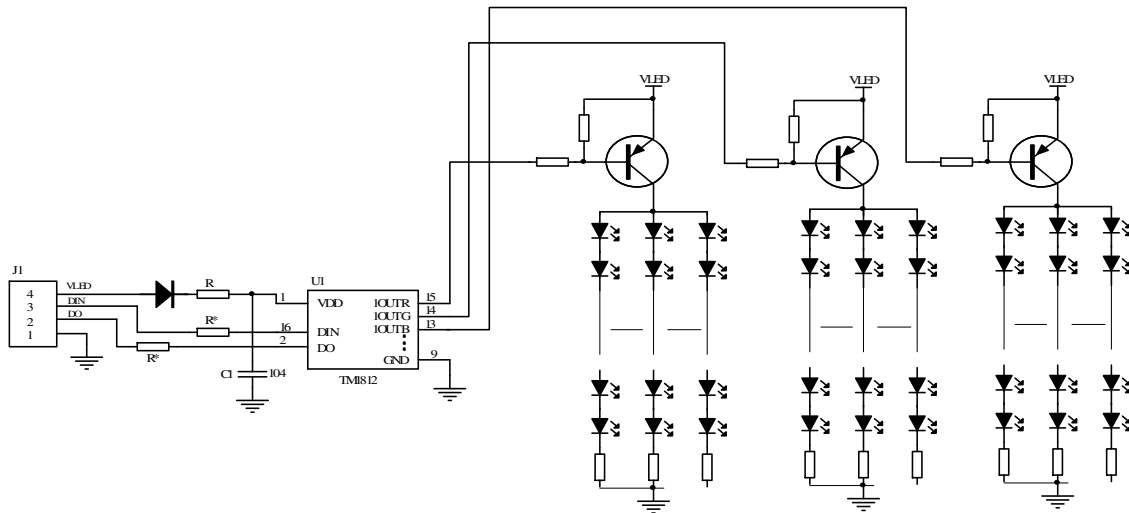



Packaging illustration  
 SOP16

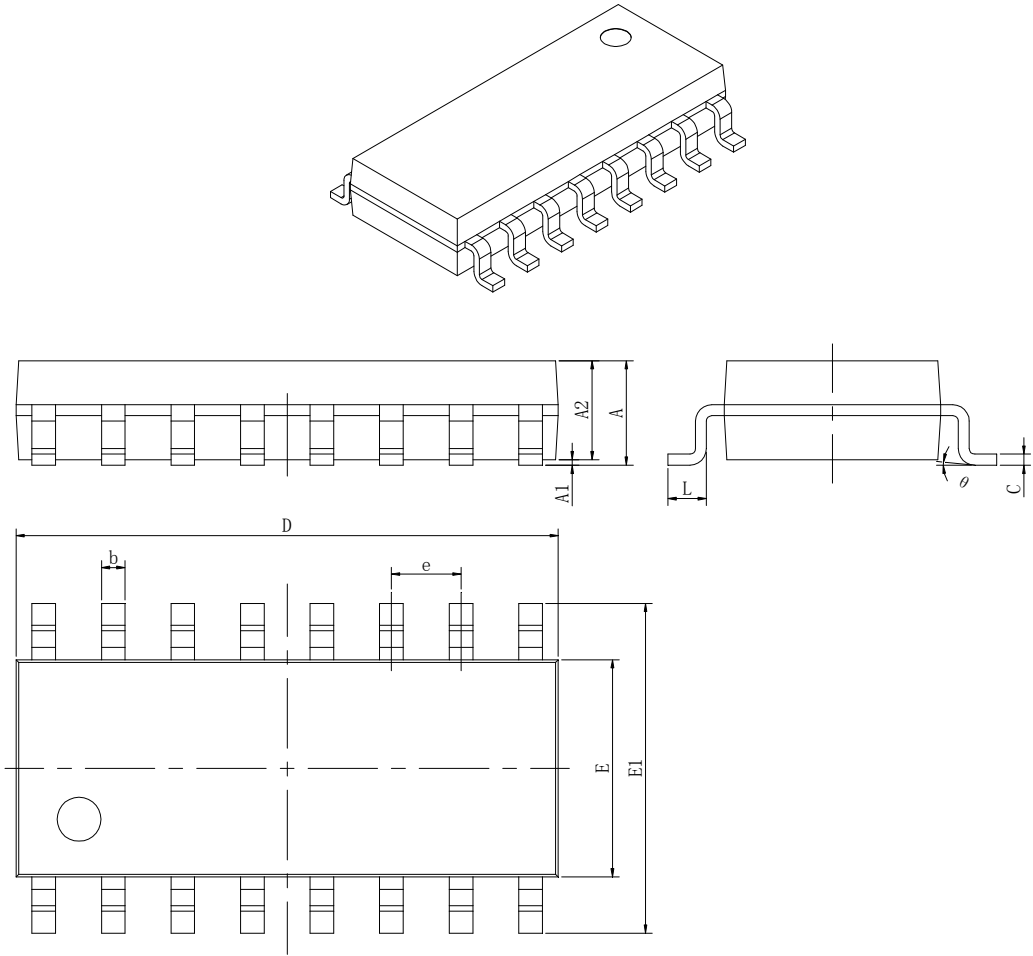

Symbol	Dimensions In Millimeters		Dimensions In Inches	
	Min	Max	Min	Max
A	1.350	1.750	0.053	0.069
A1	0.100	0.250	0.004	0.010
A2	1.350	1.550	0.053	0.061
b	0.330	0.510	0.013	0.020
c	0.170	0.250	0.007	0.010
D	9.800	10.200	0.386	0.402
E	3.800	4.000	0.150	0.157
E1	5.800	6.200	0.228	0.244
e	1.270(BSC)		0.050(BSC)	
L	0.400	1.270	0.016	0.050
θ	0°	8°	0°	8°

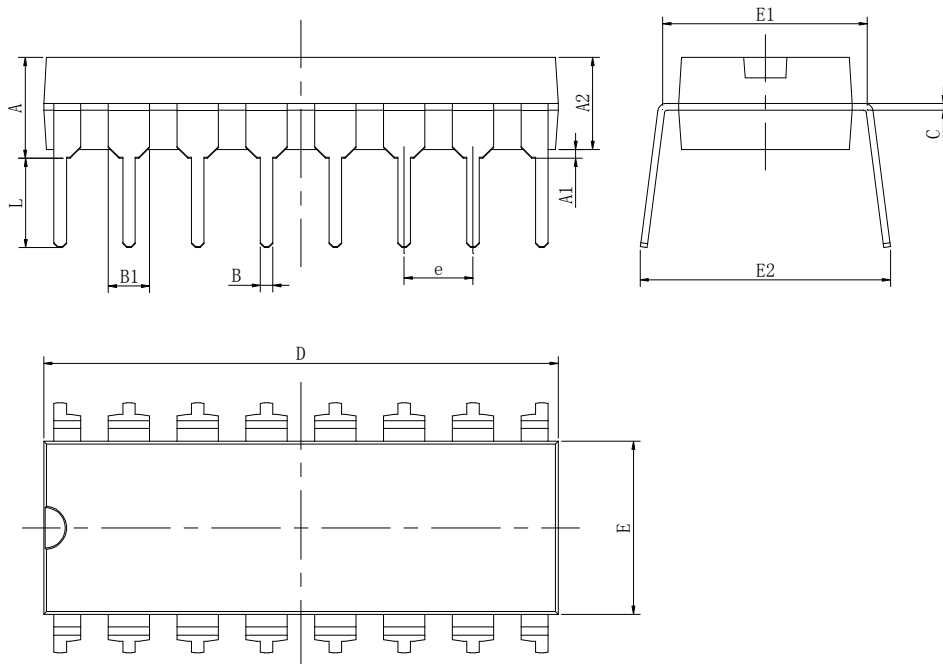
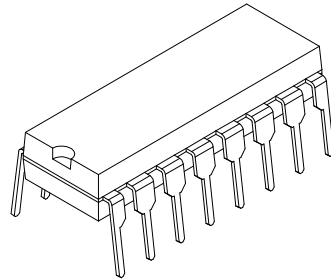

Symbol	Dimensions In Millimeters		Dimensions In Inches	
	Min	Max	Min	Max
A	3.710	4.310	0.146	0.170
A1	0.510		0.020	
A2	3.200	3.600	0.126	0.142
B	0.380	0.570	0.015	0.022
B1	1.524(BSC)		0.060(BSC)	
C	0.204	0.360	0.008	0.014
D	18.800	19.200	0.740	0.756
E	6.200	6.600	0.244	0.260
E1	7.320	7.920	0.288	0.312
e	2.540(BSC)		0.100(BSC)	
L	3.000	3.600	0.118	0.142
E2	8.400	9.000	0.331	0.354

All specs and applications shown above are subject to change without prior notice.